

1

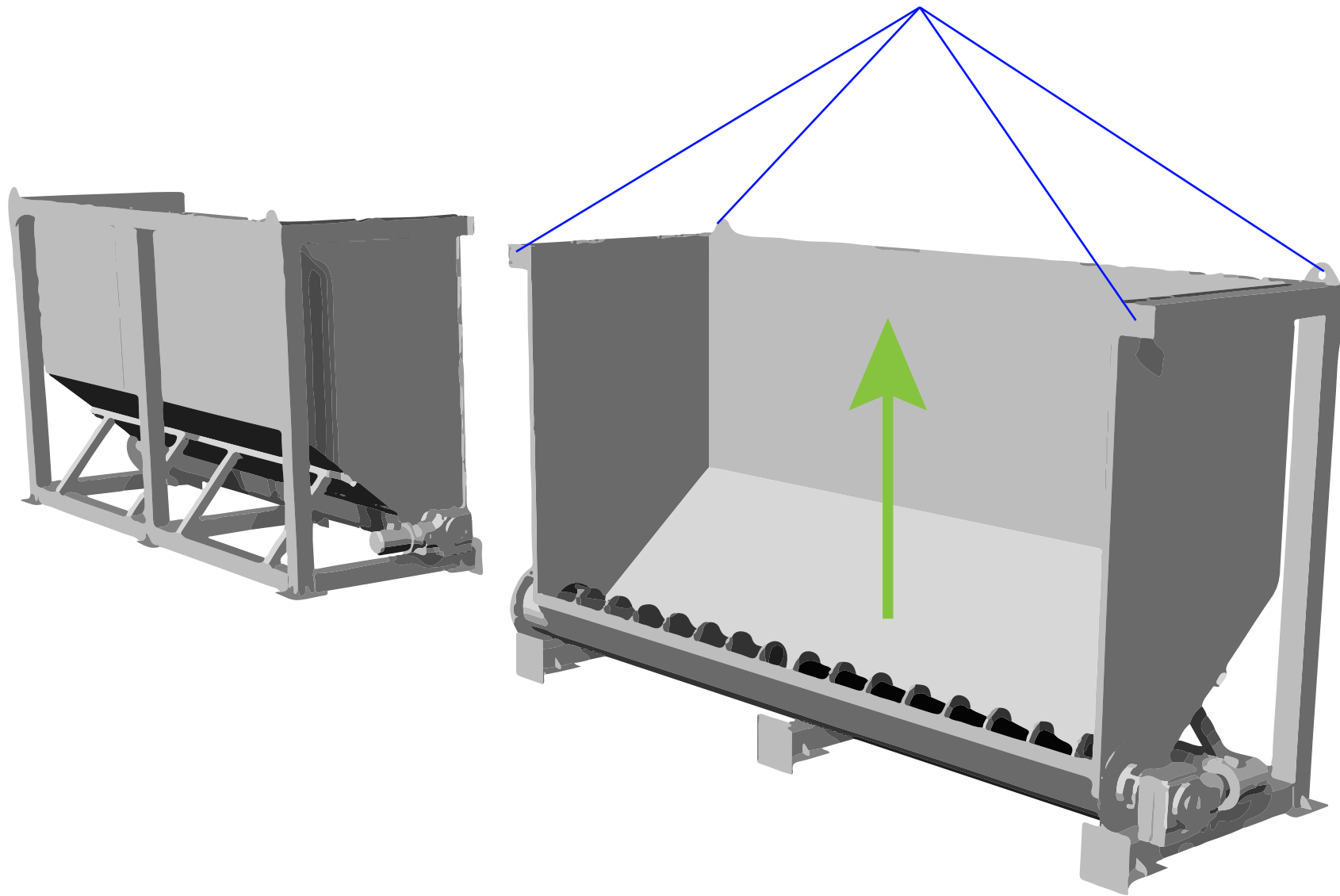

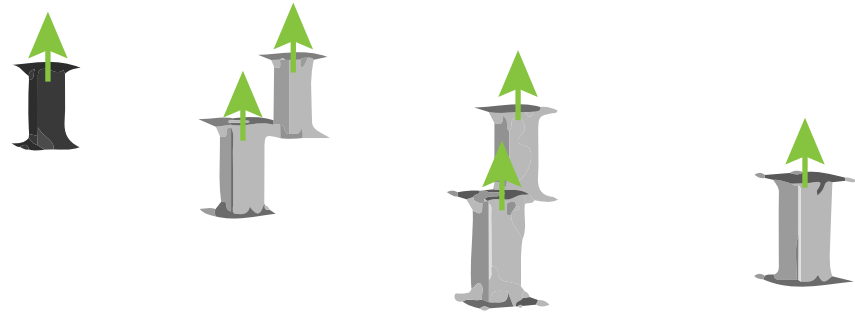

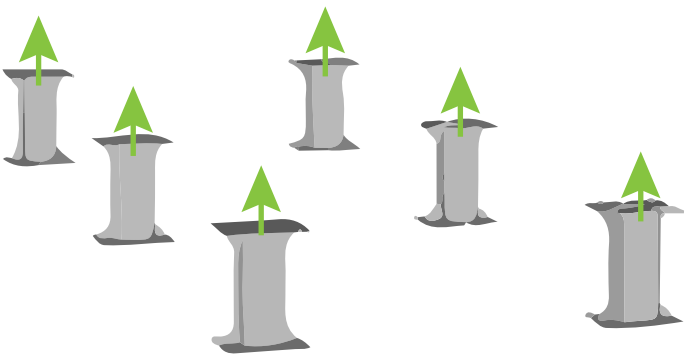
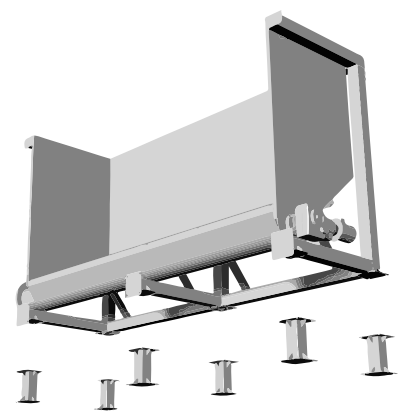
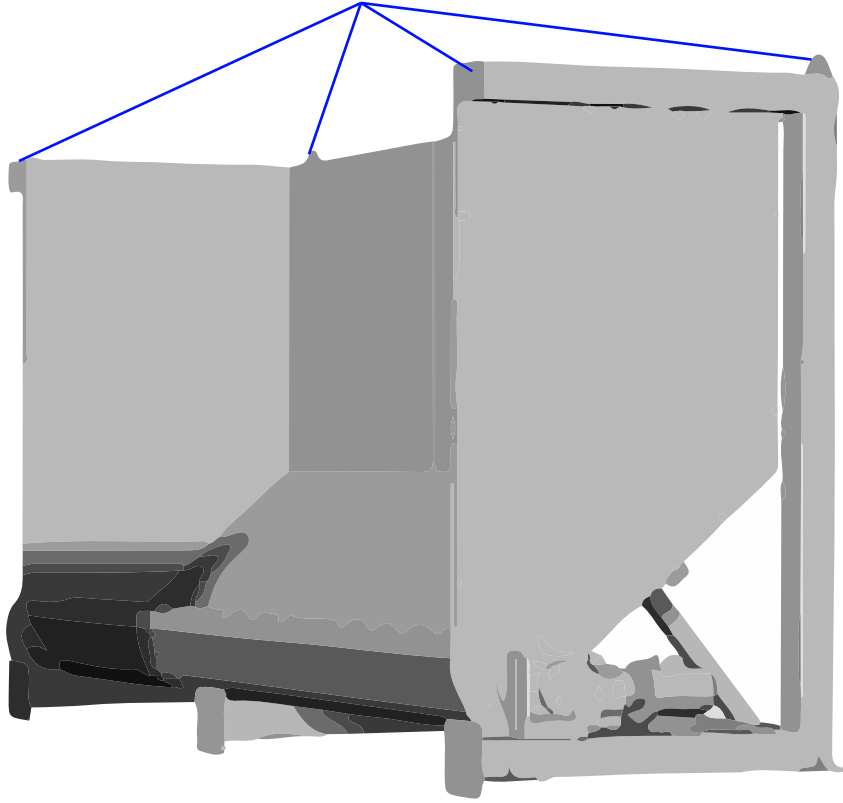
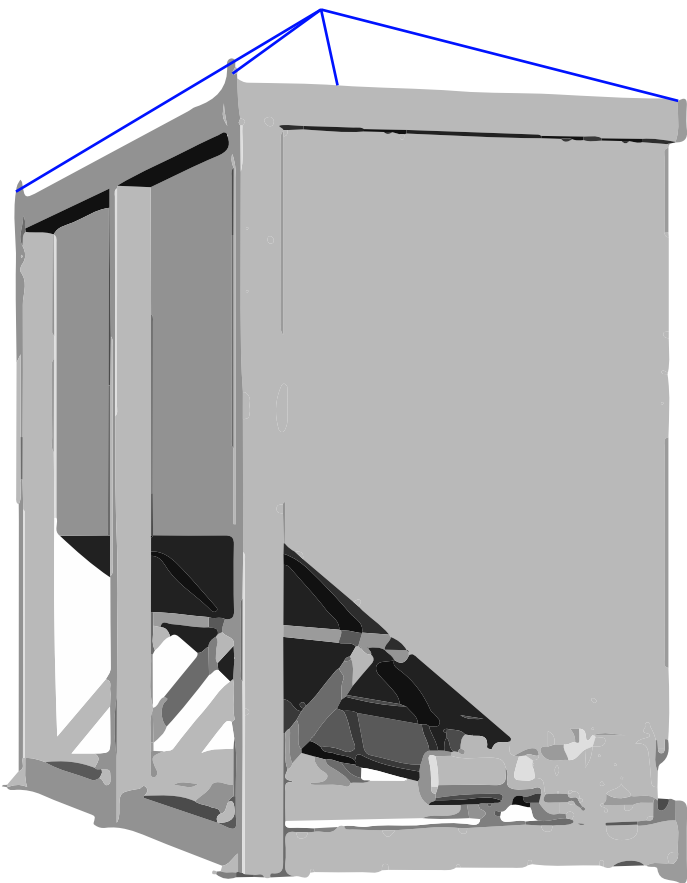
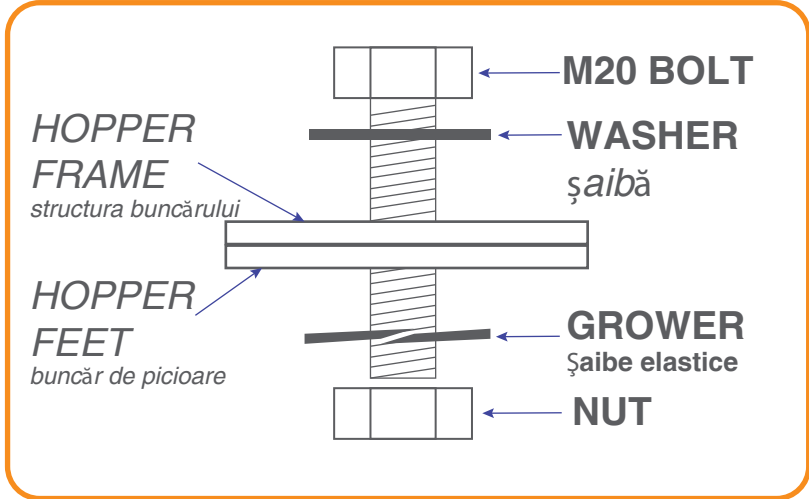

4



**PLACE FOAM ROLL
ON THE SILICON,
ALONG THE FLANGE**
*PLACE FOAM ROLL
PE SILICON,
ÎNTRE FLÂNGĂ*

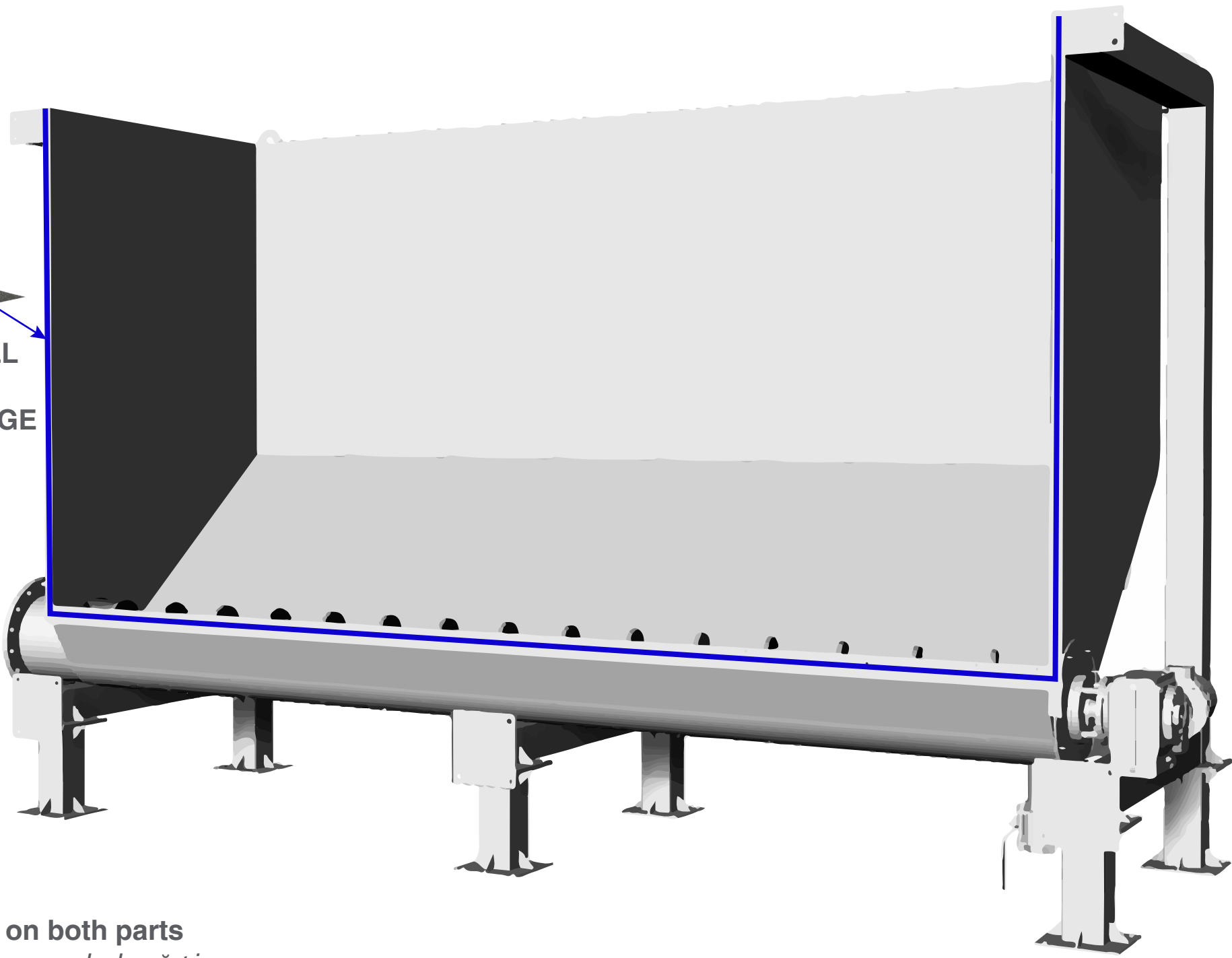

on both parts
pe ambele părți

5

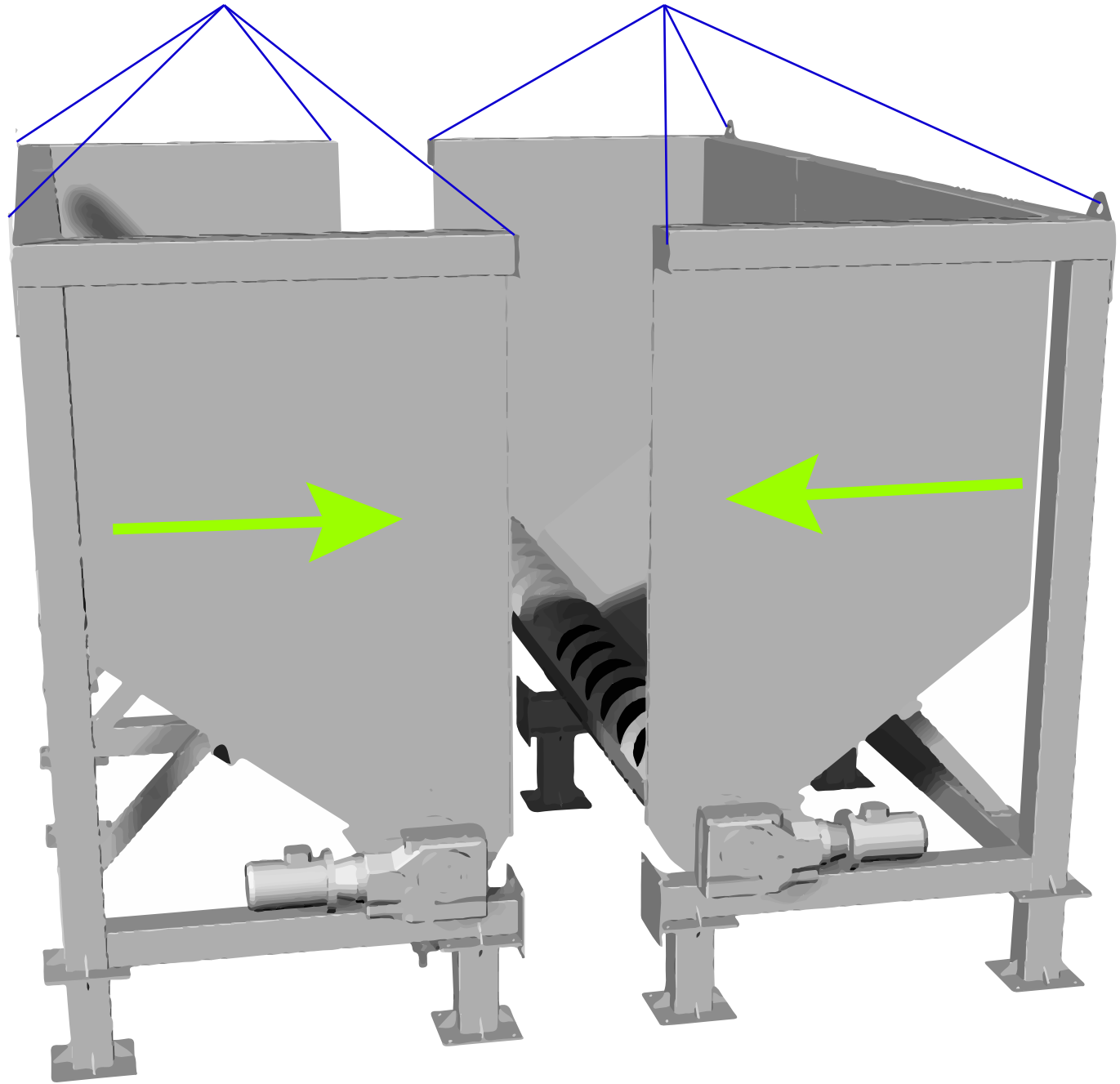

6

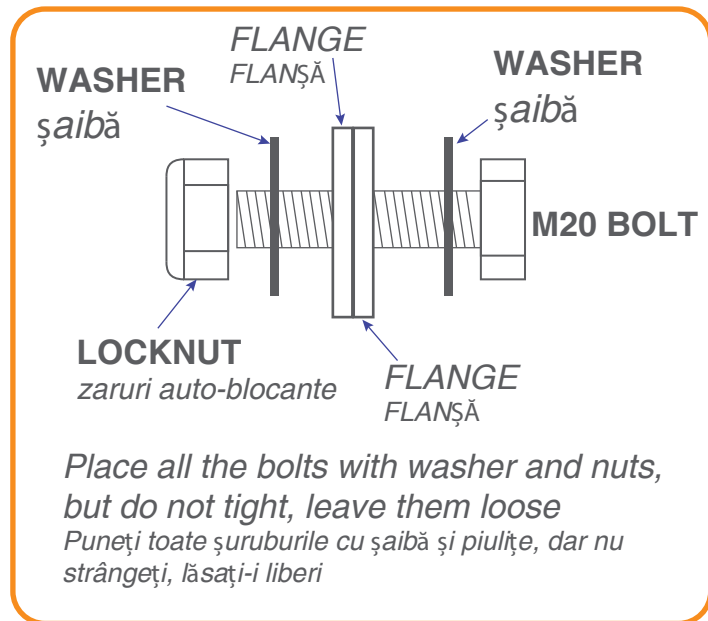
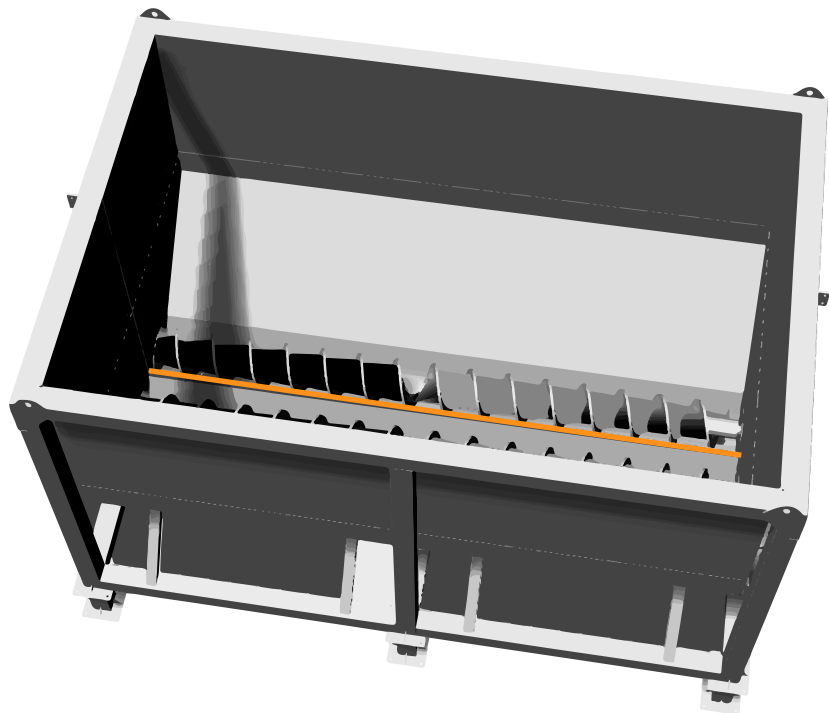
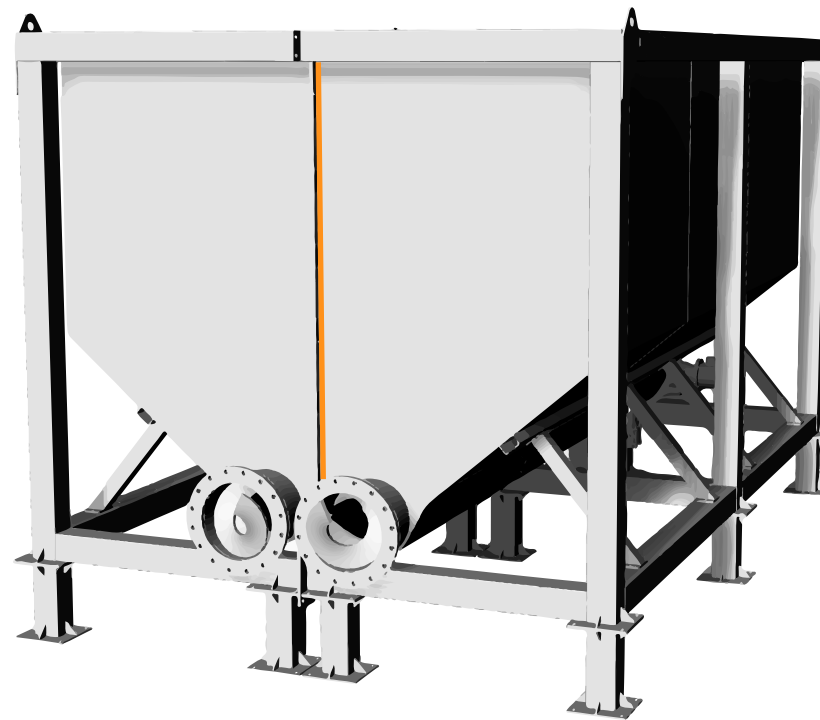
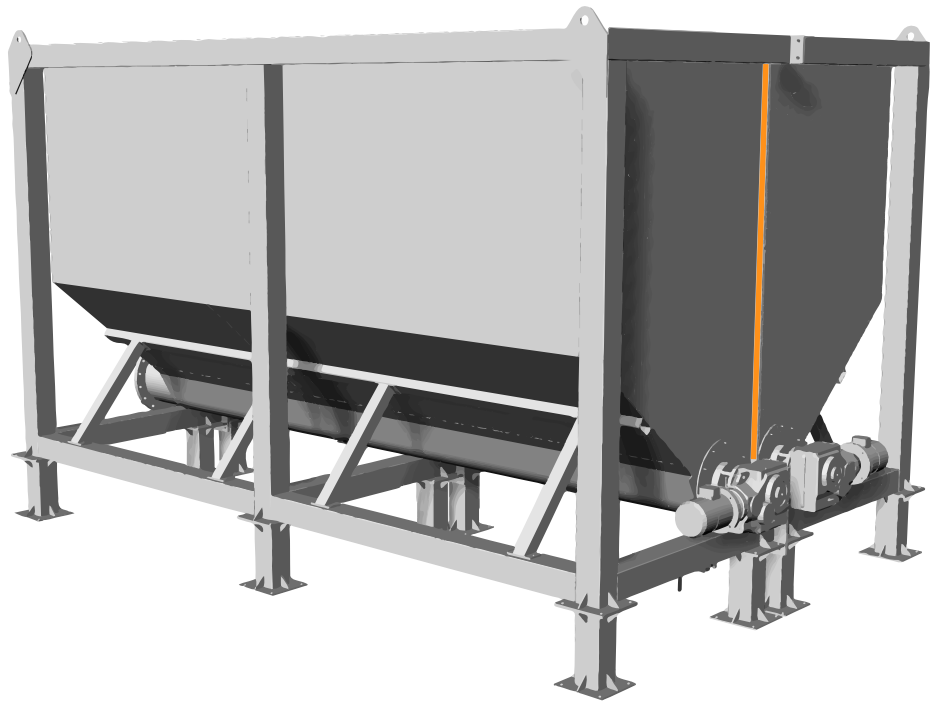

7

Begins to tighten the frame first and then moves on the tank flange
Începe să strângă mai întâi cadrul și apoi se deplasează pe flanșa rezervorului

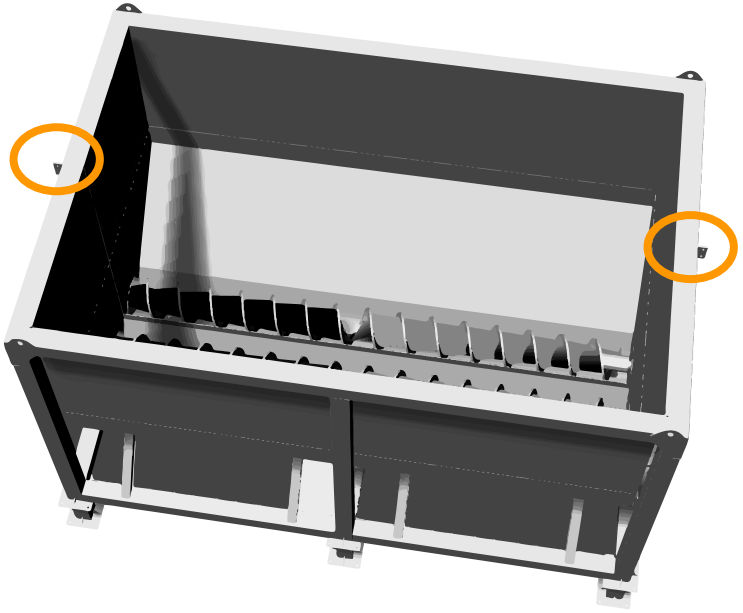
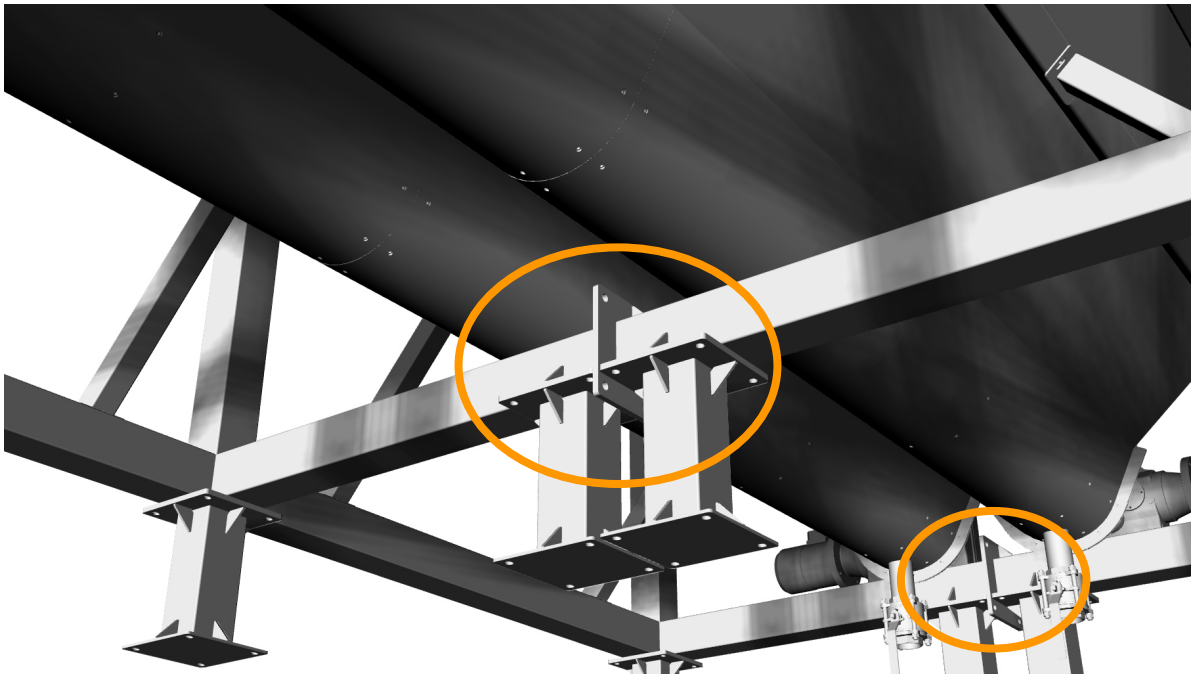

8

Tighten all the tank flanges
Strângeți toate flanșele rezervorului

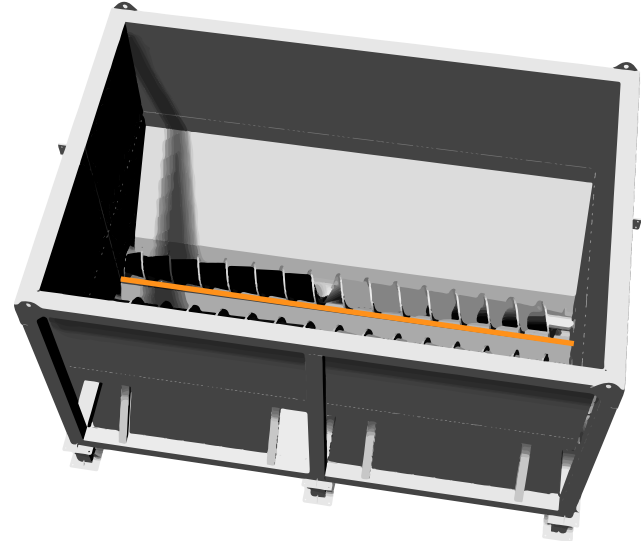
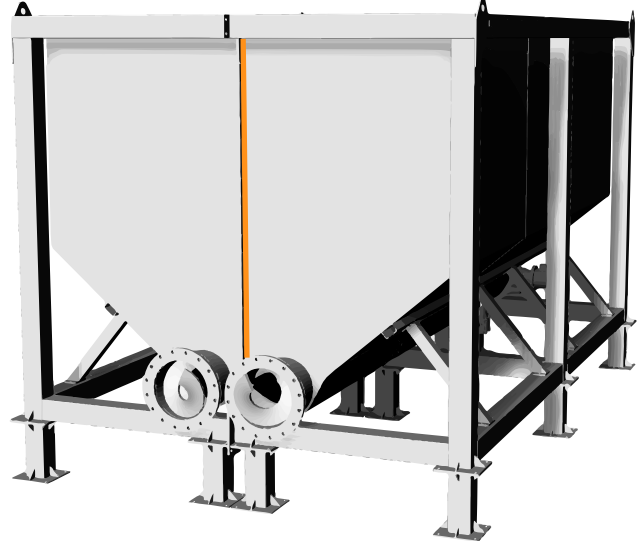
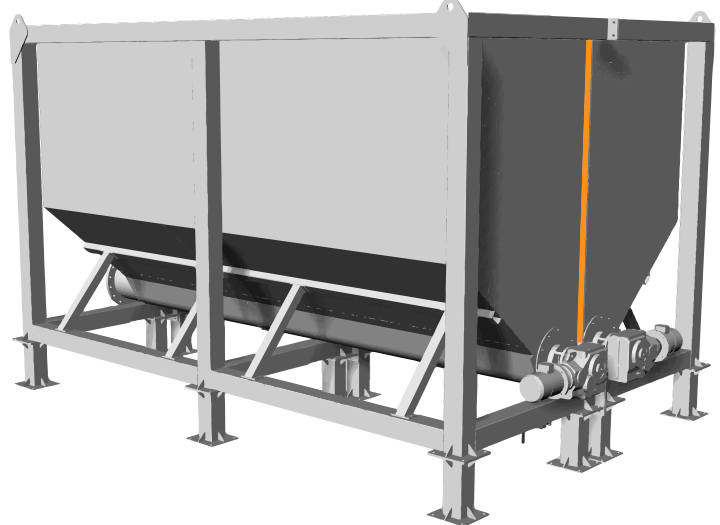

9

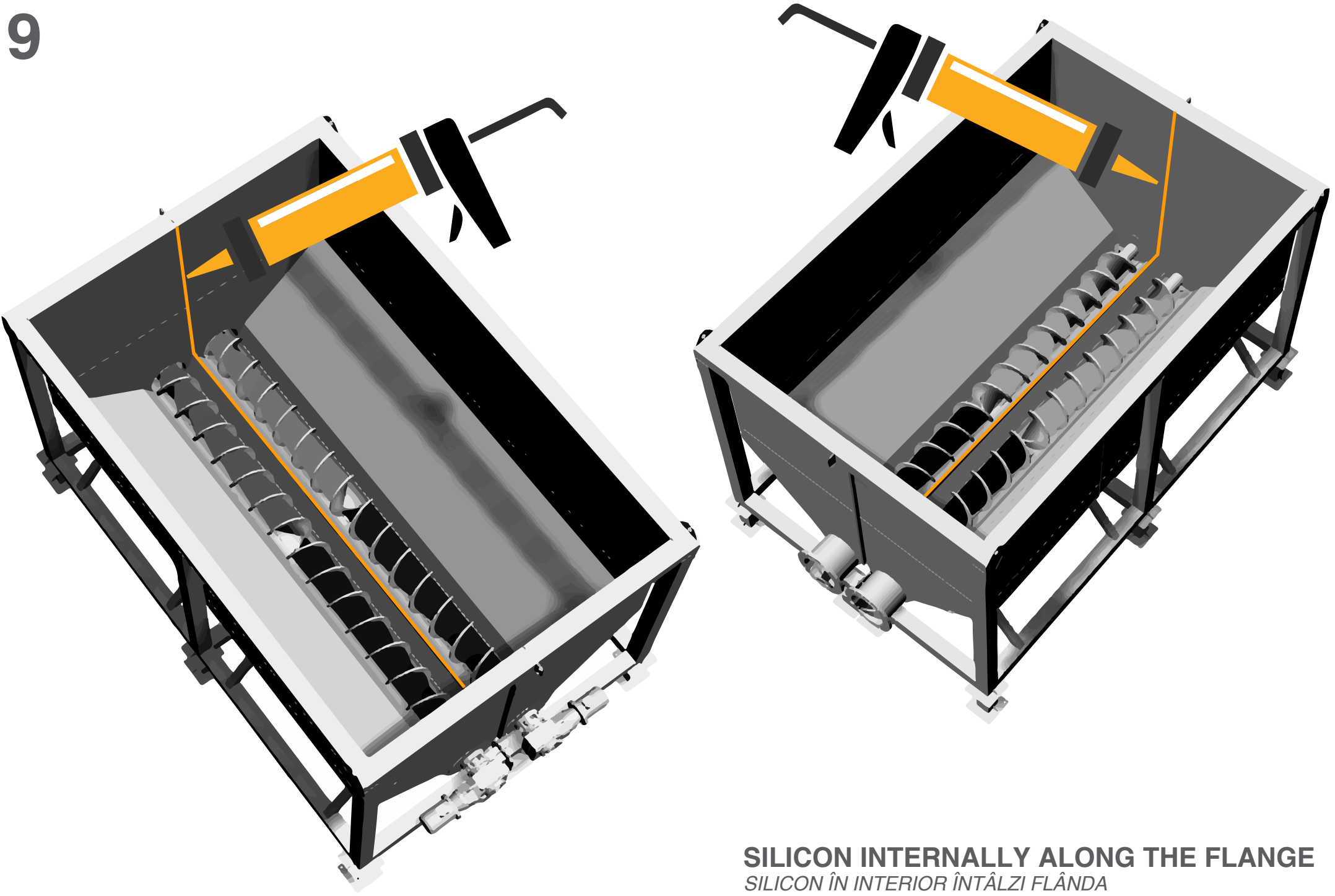

SILICON INTERNALLY ALONG THE FLANGE
SILICON ÎN INTERIOR ÎNTÂLZI FLÂNDĂ

10

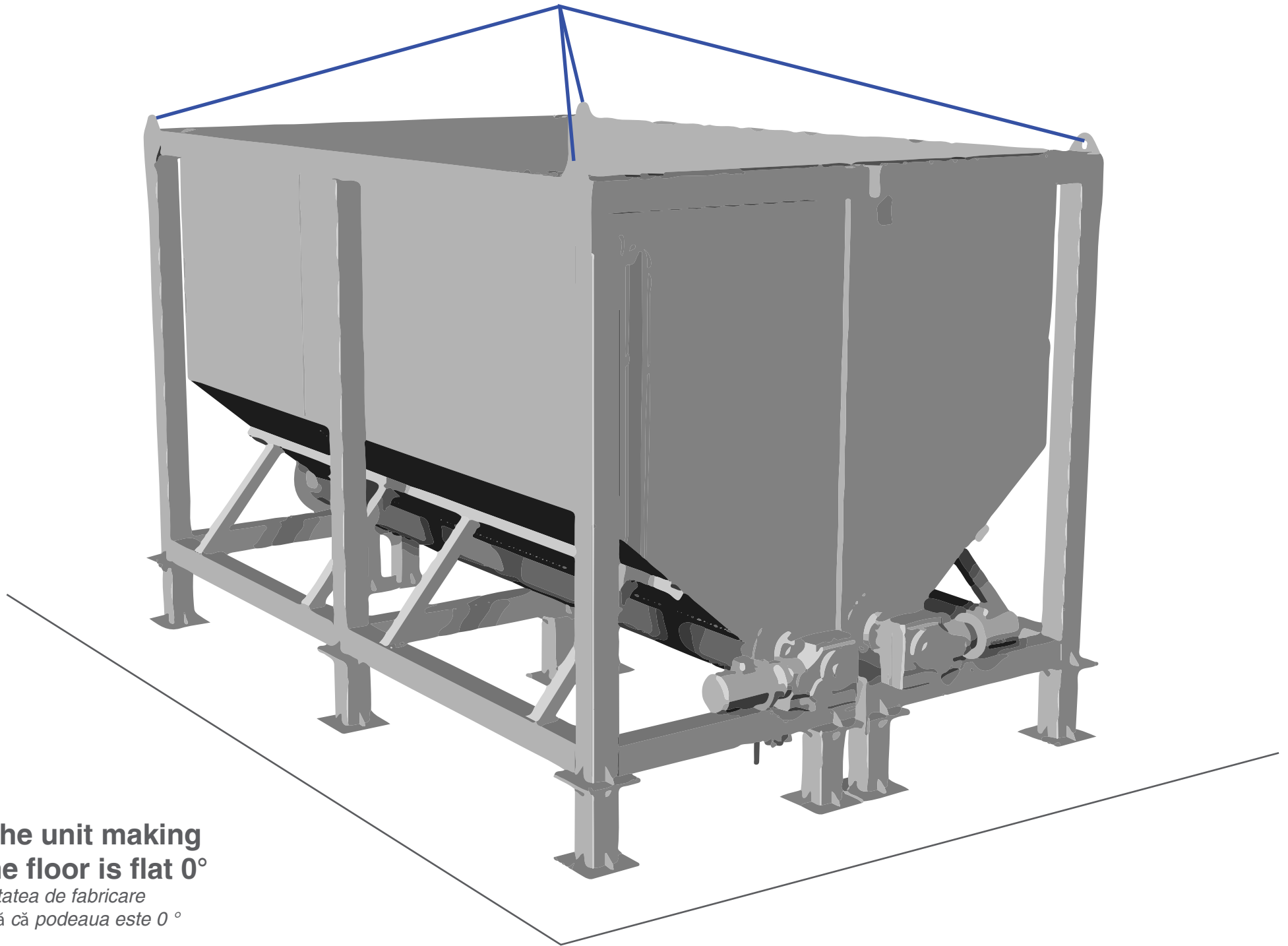

**Place the unit making
sure the floor is flat 0°**

*Plasați unitatea de fabricare
asigurați-vă că podeaua este 0°*